

M&S Systems

Model MC800
Master Unit

Owner's Guide

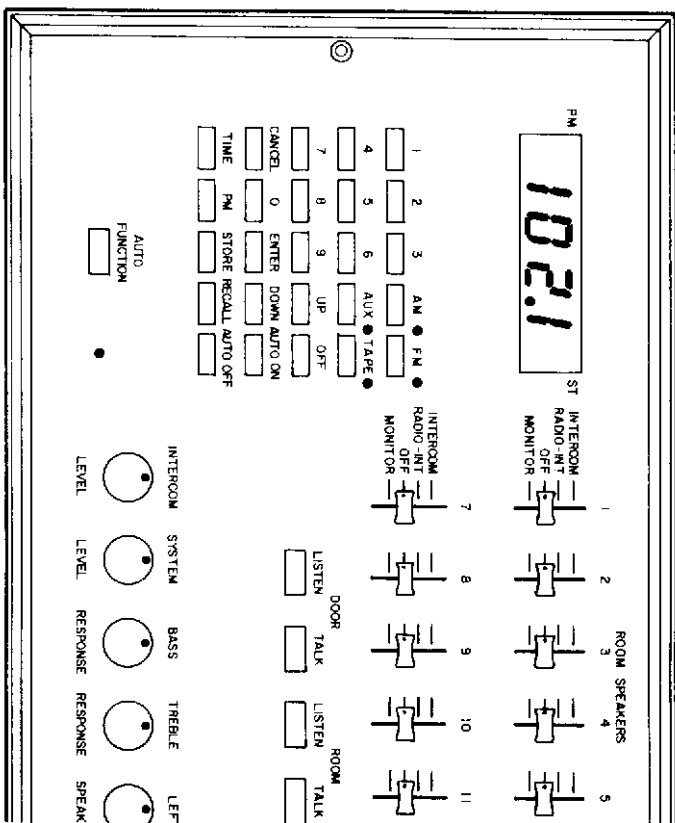

SYSTEMS, INC.

A NORTEK COMPANY
2861 Congressman Lane
Dallas, Texas 75220

This booklet contains the information you need to get the most from your musical intercom system. It also tells you what to do if your system develops operating problems, and contains applicable statements of warranty. Retain this booklet for future reference.

Contents

About Your MC800 Musical Intercom System	1
Master Unit Controls, Indicators, and Features	2
Operating the Model MC800 Master Unit	7
How to Use the Clock Radio Function	7
How to Use the Intercom Function	12
How to Use the Optional Door Chime Function	15
How to Correct Master Unit Operating Problems	16
Statements of Warranty	17

STATEMENTS OF WARRANTY

LIFETIME LIMITED WARRANTY PRODUCTS

Central Vacuum Power Units, Musical Intercom Master Units, Compact Disc Player, Cassette Tape Player, and Built-In 2-way 8-ohm Flush Mount Speakers

M&S Systems, Inc., warrants to the original homeowner for as long as he owns his home, its products to be free from factory-cause defects of material and workmanship. M&S Systems, Inc., will repair or replace, at its option, parts and/or materials at no charge should they, upon examination, be determined to be defective.

M&S Systems, Inc., reserves unto itself the sole right to make the final decision whether there is a defect in materials or workmanship and whether or not the product qualifies for the warranty.

M&S Systems, Inc., will not be responsible for any service call charges arising from the installation or repair company to the homeowner.

Defective product must be returned to the installing dealer or distributor by the homeowner. Transportation/freight charges on products submitted for replacement or repair are the customer's responsibility.

ONE YEAR LIMITED WARRANTY PRODUCTS

Vacuum accessories, Video Door intercoms, Musical Intercom Accessories, Speakers, Ironing Centers, Wall Sales, System 2000 Intercoms.

WARRANTY EXCLUSIONS

M&S Systems, Inc.'s Limited Warranty does not apply to product damage or failure caused by acts of God, misuse, abnormal usage, normal wear, faulty installation, improper maintenance, or any repairs other than repairs made by an authorized M&S repair center. This Limited Warranty will not apply to any M&S Systems, Inc. product which has been used in violation of any electrical code or Vacuum Power Units, Musical Intercom Master Units, or Speakers installed with NON-M&S Systems' brand wire or wall housings.

These warranties are for the sole and exclusive use of products in a residential installation. The Limited Warranty covers only the liability described above, and does not include liability for incidental or consequential damages.

IMPORTANT: All M&S wire and Cable Products are U.L. Approved

Master Unit Controls, Indicators, and Features

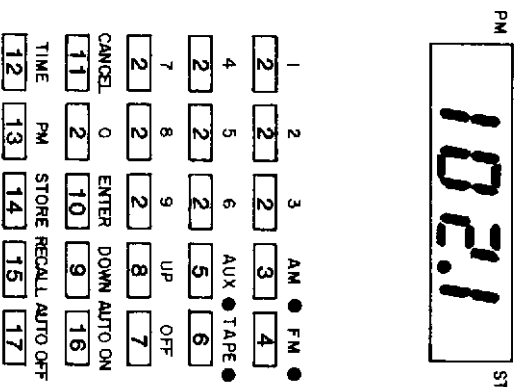

Figure 2. Master Unit Controls, Indicators, and Features

- 1 Digital Time/Frequency Display
Displays time (except when selecting radio frequencies), radio frequencies, PM, and ST (stereo).
- 2 Frequency/Time Select buttons
Pressed to:
 - Program radio AM or FM operating frequencies into computer memory (when Digital Time/Frequency display 1 shows radio frequency).

- Recall preselected AM or FM frequencies from computer memory (when Digital Time/Frequency display **1** shows radio frequency and when Recall button **15** has first been pressed).
- Set clock time, Auto On time, or Auto Off time (when Digital Time/Frequency display **1** shows Time mode).

- 3** AM button
Pressed to display selected AM frequency on Digital Time/Frequency display **1**. Indicator light illuminates when AM button is pressed.
- 4** FM button
Pressed to display selected FM frequency on Digital Time/Frequency display **1**. Indicator light illuminates when FM button is pressed.
- 5** Aux button
Pressed to allow audio input from auxiliary source (such as a phonograph). Radio is muted and indicator light illuminates when Aux button is pressed.
- 6** Tape button
Pressed to allow audio input from tape player. Radio is muted and indicator light illuminates when Tape button is pressed.
- 7** Off button
Pressed to manually turn radio off. Digital Time/Frequency display **1** displays Time mode when Off button is pressed.

How to Use the Optional Door Chime Function

Your Model MC800 Master Unit may be equipped with either a three-note or an eight-note chime. This optional chime rings through the Master Unit or any room unit and mutes the radio when the doorbell button is pressed. At least one speaker (Master Unit or room unit) must be ON for the Door Chime to function. The Room Speaker Station switches **20** must be in either the RADIO-INT or INTERCOM position. Volume for the three-note or eight-note chime is controlled with the Speaker Volume knobs **26** and **27** on the Master Unit with the Volume Control knob **33** on the room units.

How to Correct Master Unit Operating Problems

Problem	What to Check For
No AM or FM reception	<ol style="list-style-type: none"> 1. AM button 3 or FM button 4 not in correct position. 2. Aux button 5 or Tape button 6 not in correct position. 3. Off button 7 not in correct position.
Display flashing	Loss of electrical power. (Check and reprogram clock and radio frequencies.)
Feedback or squeal	Intercom Level knob 22 on master unit adjusted too high.
Weak or no intercom	<ol style="list-style-type: none"> 1. Intercom Level knob 22 on Master Unit not adjusted correctly. 2. Room Speaker Station switches 20 not in correct position (INTERCOM, RADIO-INT, OFF, or MONITOR). 3. Volume Control knob 33 on room unit not adjusted correctly.

Step 4 To listen to the Master Unit from the room unit, press and hold the Rooms Listen button **36** on the room unit.

Note: The radio mutes during communication.

Monitoring Room Units

A unique feature of the Model MC800 is the monitor function. This sets the Master Unit in a continuous "Listen" mode, which is helpful when caring for children or sick persons. To monitor any or all room units, set the corresponding Room Speaker Station switches **20** to the MONITOR position. Volume is controlled with the Intercom Level knob **22**.

Communicating with the Door Unit

Communication with the door unit is possible from the Master Unit or the room units. This feature allows you to screen visitors from the safety of your home.

From the Master Unit

Step 1 To talk to the door unit, press and hold the Door Talk button **29**.

Step 2 To listen to the door unit, press and hold the Door Listen button **28**.

Note: The radio mutes during communication.

From Room Units

Note: To communicate with the door unit from the room units, the Room Speaker Station switches **20** on the Master Unit must be in the RADIO-INT or INTERCOM position.

Step 1 To talk to the door unit, press and hold the Door Talk button **35**.

Step 2 To listen to the door unit, press and hold the Door Listen button **34**.

Note: The radio mutes during communication.

8 Up button

Pressed to scan "up" (toward higher numbers) when selecting AM or FM frequency. Automatically stops at next frequency with enough signal strength to stop scan.

9 Down button

Pressed to scan "down" (toward lower numbers) when selecting AM or FM frequency. Automatically stops at next frequency with enough signal strength to stop scan.

10 Enter button

Pressed to enter preselected times (clock time, Auto On, and Auto Off) and preselected frequencies (AM or FM) into computer memory.

11 Cancel button

Pressed to cancel errors committed when entering preselected times or frequencies into computer memory.

12 Time button

Pressed to place the Master Unit in Time mode. Used with Frequency/Time Select buttons **2** to set clock time, which is displayed on Digital Time/Frequency display **1**.

13 PM button

Pressed to enter correct PM time when Master Unit is placed in Time mode. Indicator light illuminates to indicate PM time on Digital Time/Frequency display **1**.

14 Store button

Pressed to store 10 AM and 10 PM frequencies in computer memory. Preselected frequencies are entered into computer memory using Frequency/Time Select buttons **2**.

15 Recall button

Pressed to set Master Unit to Recall mode prior to using Frequency/Time Select buttons **2** to recall preselected frequencies from computer memory.

- 16** Auto On button
Pressed to set time for radio to turn on automatically (Auto On function).
- 17** Auto Off button
Pressed to set time for radio to turn off automatically (Auto Off function).
- 18** Auto Function button
Pressed to place Master Unit in Auto mode for use of Auto On and Auto Off functions. Auto On or Auto Off indicator light illuminates to indicate Auto mode.

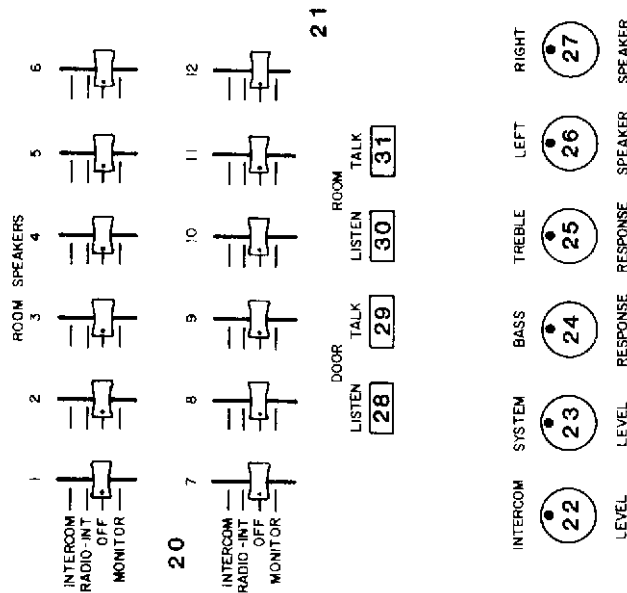

Figure 3. Master Unit Controls, Indicators, and Features

- 19** Computer Reset button
Pressed to reset computer in event Digital Time/Frequency display 1 is locked and there is no response from any function keys.

- 36** Rooms Listen button
Allows communication between the room units and the Master Unit. The button must be pressed and held to listen to other room units, but not to listen to the Master Unit.
- 37** Rooms Talk button
Allows communication between the room units and the Master Unit. The button must be pressed and held to talk to the Master Unit or room units.

Step 1 Rotate the Intercom Level knob **22** on the Master Unit to a level that allows voice communication between the Master Unit and the room units.

Here's a Tip: Set the Intercom Level knob between the 12 o'clock and 1 o'clock positions. This setting should help eliminate "feedback" or "squeal." Once the desired setting is made, no further adjustment is necessary.

- Step 2** Adjust the volume of the room units by turning the Volume Control knob **33** to the desired setting.
- Step 3** Adjust the Master Unit volume by turning the Left **26** and Right **27** Speaker Volume knobs to the desired setting.

Communicating with Room Units

Note: Communication is "Hands Free" for the receiving party. The person initiating the call operates the buttons. Room selectivity for personal conversation is possible from the Master Unit only by placing all Room Speaker Station switches **20** in the OFF position, except the room units you wish to communicate with. RADIO-INT is the normal position of the Room Speaker switches **20** when communicating with the room units.

- Step 1** To talk to room units from the Master Unit, press and hold the Room Talk button **31** on the Master Unit.
- Step 2** To listen to the room units from the Master Unit, press and hold the Room Listen button **30** on the Master Unit.
- Step 3** To talk to the Master Unit from the room unit, press and hold the Rooms Talk button **37** on the room unit.

Adjusting Intercom Volume

Figure 4 shows the controls you use to operate the room units.

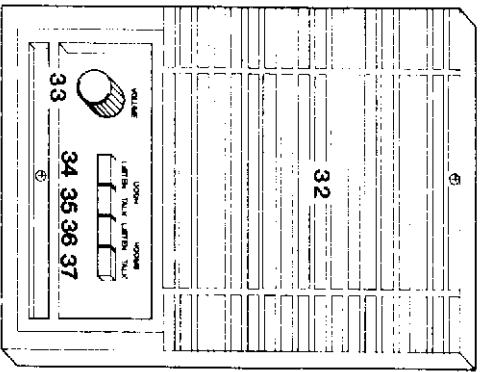

Figure 4. Room Unit

- 32** Combination Speaker/Microphone
Provides speaker for both radio and intercom. Provides microphone for intercom.
- 33** Volume Control knob
Rotates to adjust the speaker volume.
- 34** Door Listen button
Activates communication between the door unit and the room unit. The button must be pressed and held to listen to the door unit.
- 35** Door Talk button
Activates communication between the door unit and the room unit. The button must be pressed and held to talk to the door unit.

- 20** Room Speaker Station switches

Twelve switches set to any of four positions to select operating mode of corresponding room units:

INTERCOM For intercom and door chime reception only, with no radio reception.

RADIO-INT Normal intercom and radio reception.

OFF Room unit is turned off.

MONITOR For monitoring rooms from Master Unit and rooms whose units are set in RADIO-INT position.

- 21** Microphone

For intercom communication.

- 22** Intercom Level knob

Adjusts overall volume of entire intercom system.

- 23** System Level knob

Adjusts overall radio volume throughout entire system.

- 24** Base Response knob

Adjusts radio bass.

- 25** Treble Response knob

Adjusts radio treble.

- 26** Left Speaker Volume knob

Adjusts left speaker volume.

- 27** Right speaker Volume knob

Adjusts right speaker volume.

Note: The Model MC800 does not include speakers. Stereo speakers are mounted separately from Master Unit.

- 28** Door Listen button

Pressed and held to listen to door unit from Master Unit.

- 35** Door Talk button Pressed and held to talk to door unit from Master Unit.
- 36** Room Listen button Pressed and held to listen to room unit from Master Unit.
- 37** Room Talk button Pressed and held to talk to room unit from Master Unit.

Operating the Model MC800 Master Unit

Your Master Unit operates with two standard functions and one optional function:

- Clock radio
- Intercom
- Door chime (optional).

This section explains how to use these functions.

How to Use the Clock Radio Function

The clock radio in your Master Unit receives both AM- and FM-band frequencies. It also works in combination with the intercom.

Setting the Time

Press the Time button **12** followed by the numbers corresponding to the correct time, then press the Enter button **10**.

Example: Assume that the correct time of day is 8:30 A.M. On the keypad, press:



The display reads: **8:30**

The display reads:

with the colon flashing once every 2 seconds.

Resetting Memory Selections After a Power Failure

A temporary power failure does not erase the computer memory selections. The clock stops at the time of the power failure and displays the failure time when power is restored. At that point, the clock continues to count. However, the displayed time is flashing, indicating that a power failure has taken place. The correct time must then be re-entered. An extended power failure results in a loss of all computer memory functions. Start from the beginning, and reprogram the system.

Resetting the Computer After a "Lock-Up" Error

If there is no response from the Frequency/Time Select buttons **2**, or if the Digital Time/Frequency display is showing 18:88 or another erroneous indication, an electrical power fluctuation (such as a power surge) has caused the computer to "lock up." You can reset the computer using a paper clip or a small jeweler's screwdriver. Insert a paper clip or screwdriver in the hole provided and press the Computer Reset button **19**.

How to Use the Intercom Function

The 20-speaker, 12-station capacity intercom allows you to communicate with any room, answer the door unit from any room, or monitor one or more speakers from any combination of room speakers. The intercom functions are always ON. The intercom and optional door chimes operate 24 hours a day, even when the radio is turned off.

Setting up the Intercom

To set up the intercom, place the Room Speaker Station switches **20** to the desired position (INTERCOM, RADIO-INT, OFF, OR MONITOR). The normal ON position is RADIO-INT, which allows all functions (radio, door chimes, and intercom) to operate.

Setting the Radio to Turn On or Off Automatically

This feature allows you to preset the clock to turn on and off automatically. The Auto Function button **18** must be ON to activate this feature. There is a red indicator light to the right of the button, which illuminates when the Auto Function is ON.

Step 1 Assume that you want the radio to turn on automatically at 6:00

A.M. On the keypad, press:

The display returns to real time as soon as you press the Enter button **10**.

Step 2 Assume that you want the radio to turn off automatically at 10:00

P.M. On the keypad, press:

The display returns to real time as soon as you press the Enter button **10**.

Note: To verify the Auto On or Auto Off time, press either the Auto On **16** or Auto Off **17** button. The programmed time is displayed. The display returns to real time after a few seconds.

If the times set in the Auto Function are to be repeated each day, leave the Auto Function button ON. It is not necessary to reprogram the same settings daily. To terminate the Auto Function, press the Auto Function button OFF. The indicator light turns off, and the Automatic On/Off feature ceases to operate.

Example: Assume that the correct time of day is 8:30 P.M. On the keypad, press:

The display reads:

PM **8:30**

with the colon flashing once every 2 seconds.

Note: If you make a mistake when entering numbers, press the Cancel button **11** on the keypad and repeat the operation. In all cases you must press the Enter button **10** within 9 seconds after you enter the numbers, or that selection is lost and must be rekeyed.

Turning the Radio On and Adjusting Volume

Step 1 To turn the radio on, press either the AM **3** or FM **4** button. Pressing the Off button **7** turns the radio off.

Step 2 To adjust the radio volume of the Master Unit, rotate the Left **26** and Right **27** Speaker Volume knobs clockwise. Rotating the knobs counterclockwise decreases volume.

Step 3 To adjust the radio volume for the room units, rotate the System Level knob **23** clockwise. Rotating the knob counterclockwise decreases volume.

Here's a Tip: Setting the System Level knob **23** to maximum volume (fully clockwise) distorts the quality of sound at the room unit speakers. Remember that each room unit also has a volume control. For best sound quality, use a moderate system level setting at the Master Unit and adjust individual room unit volume settings as needed.

Adjusting the Tone (Bass/Treble)

You use two controls: the Bass Response knob **24**, and the Treble Response knob **25**, to adjust the tone. Rotating the Bass Response knob clockwise increases BASS. Rotating the knob counterclockwise decreases BASS. Rotating the Treble Response knob clockwise increases TREBLE. Rotating the knob counterclockwise decreases TREBLE.

Tuning the Radio

The range of the AM broadcast band is 540 to 1600 Kilohertz (KHz), and the range of the FM broadcast band is 88.1 to 107.9 Megahertz (MHz). All AM frequencies end with a zero (540, 820, 1080, etc.), and all FM frequencies end with a decimal point and an odd number (88.1, 92.5, 100.3, etc.). You can tune the radio using direct entry, automatic scan, or memory selection tuning.

Direct Entry Tuning

Step 1 Assume that you want to directly enter 102.1 FM. On the keypad, press:

The display reads:

102.1

and the red indicator light above the FM button lights automatically.

Step 2 Assume that you want to directly enter 1080 AM. On the keypad, press:

The display reads:

1080

and the red indicator light above the AM button lights automatically.

Automatic Scan Tuning

Step 1 Press either the AM **3** or FM **4** button.

Step 2 To tune the radio to a frequency higher than the one currently displayed, momentarily press (then release) the Up button **8**. The radio scans "up" to the next frequency with enough signal strength to stop the scan.

Repeat this operation until the radio is tuned to the desired frequency.

Step 3 To tune the radio to a frequency lower than the one currently displayed, momentarily press (then release) the Down button **9**. The radio scans "down" to the next frequency with enough signal strength to stop the scan.

Repeat this operation until the radio is tuned to the desired frequency.

Memory Selection Tuning

You can program up to 20 preselected frequencies (10 AM and 10 FM) into the Master Unit for immediate tuning.

Setting Memory selections

Step 1 Select a desired frequency in the AM or FM band according to the instructions under "Direct Entry Tuning" on page 9 or "Automatic Scan Tuning."

Step 2 On the keypad, press:

Step 3 Select another radio station, AM or FM, and press:

Step 4 Repeat steps 1 through 3 to program up to 10 (0 through 9) memory selections in any order you choose.

You can store another 10 stations of the opposite band in the same 0 through 9 memories. For example, if the first station stored under 1 is an AM station, you can tune to an FM station and store it under 1 by repeating steps 1 through 3.

Recalling Memory selections

To recall frequencies placed in memory, press the Recall button **15** and the desired Frequency/Time Select button **2**. The radio immediately tunes to the stored frequency, which is also shown on the Digital Time/Frequency display **1**.